



EXAMSLIDE™
High Performance Doors



Frame

Designed to protect wall opening

Handle

ADA clearances maintained

Sill

Concealed sill guide

AD Systems ExamSlide™ was specifically designed to meet the rigorous demands of today's lean healthcare medical facilities. Constructed with the highest quality, commercial grade hardware and precision engineered framing system to provide years of trouble-free service.

ADA-compliant operation, along with 'soft-close' technology, ensure that patients of all ages and abilities can easily open and close the door. AD Systems offers standard perimeter gasketing and the potential for acoustic mitigation on all four sides with our optional patent pending automatic drop seal, providing the best possible noise reduction to maintain speech privacy standards.



Standard Features

AD SYSTEMS EXAMSLIDE™ STANDARD FEATURES:

- Space-saving design saves up to 30 sq ft, when compared to a swing door
- Heavy-duty, top-hung roller system for smooth, maintenance-free operation
- Concealed floor guide - no exposed floor track
- Optional patent pending acoustic mitigation on all four sides of the door to achieve speech privacy (NIC 39); three side perimeter gasket standard
- ADA-compliant operation
- Soft-close dampening system prevents slamming
- Easy to clean aluminum frame system wraps and protects wall construction

Options

HARDWARE OPTIONS:

- ADA thumb turn lock with occupancy indicator
- ADA self-latching mortise with thumb turn and egress handle
- Key lock
- Magnetic lock for integration with key card access control

1-3/4" DOOR OPTIONS:

- Flush wood door
- Flush laminate door
- Wood stile and rail door with glass vision lite
- Glass units with integral blinds or louvers
- Lead shielding doors and glazing for X-Ray rooms

ELEVATION VIEW

Opens to left

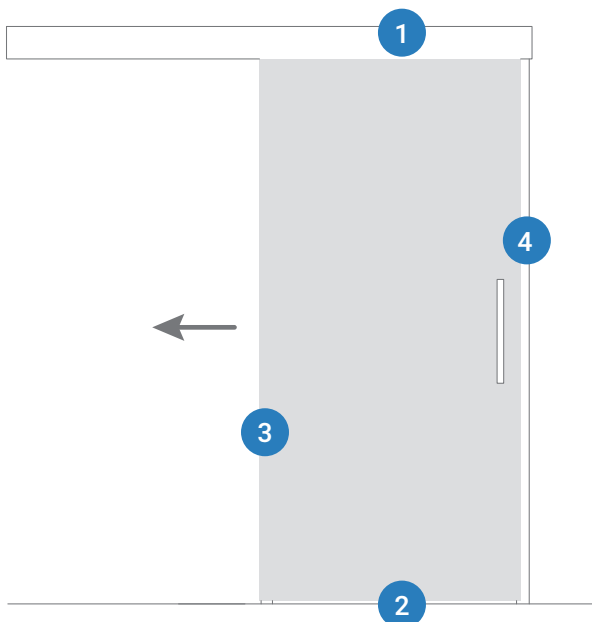

1 Head @ Opening
Typical

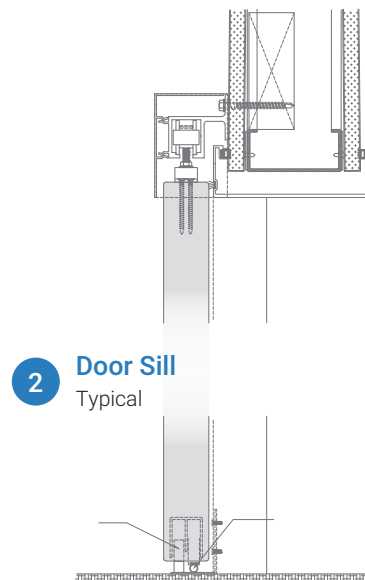

3 Jamb @ Sill Side

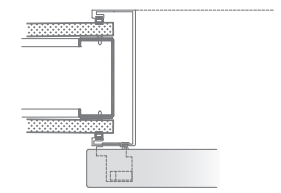

4 Jamb @ Pull Side
Typical

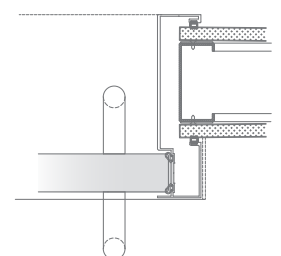



The Everett Clinic
For the whole area

FAMILY PRACTICE
Frederick Campbell, MD
Lynn Chung, MD
Morgan Smith, MD

INTERNAL MEDICINE
Talia Adams, MD
Amanda Henry, MD

OBSTETRICS & GYNECOLOGY
Melissa Anderson, MD
Lisa Martin, MD

PODIATRY
Angela Wilson, DPM

AD SYSTEMS

HIGH PERFORMANCE DOORS