



DESIGN GUIDE

MOVING DESIGN. ENDLESS POSSIBILITY

As trailblazers in the commercial sliding barn door category, AD Systems has a proven history of performance. But we never stop thinking about tomorrow.

We engineer premium, interior sliding door systems with a full range of unequaled features and unparalleled support. No shortcuts here. Our systems feature the highest-quality materials, excellent sound attenuation, commercial-grade hardware, world-class service, and a variety of functional and aesthetic options.

Continued collaboration with architects and building design professionals allows us to push the limits, providing “sliding-edge” technology and innovation in areas with privacy, accessibility, or fire safety requirements.

We are the pioneers in the industry, but we are always sliding forward.

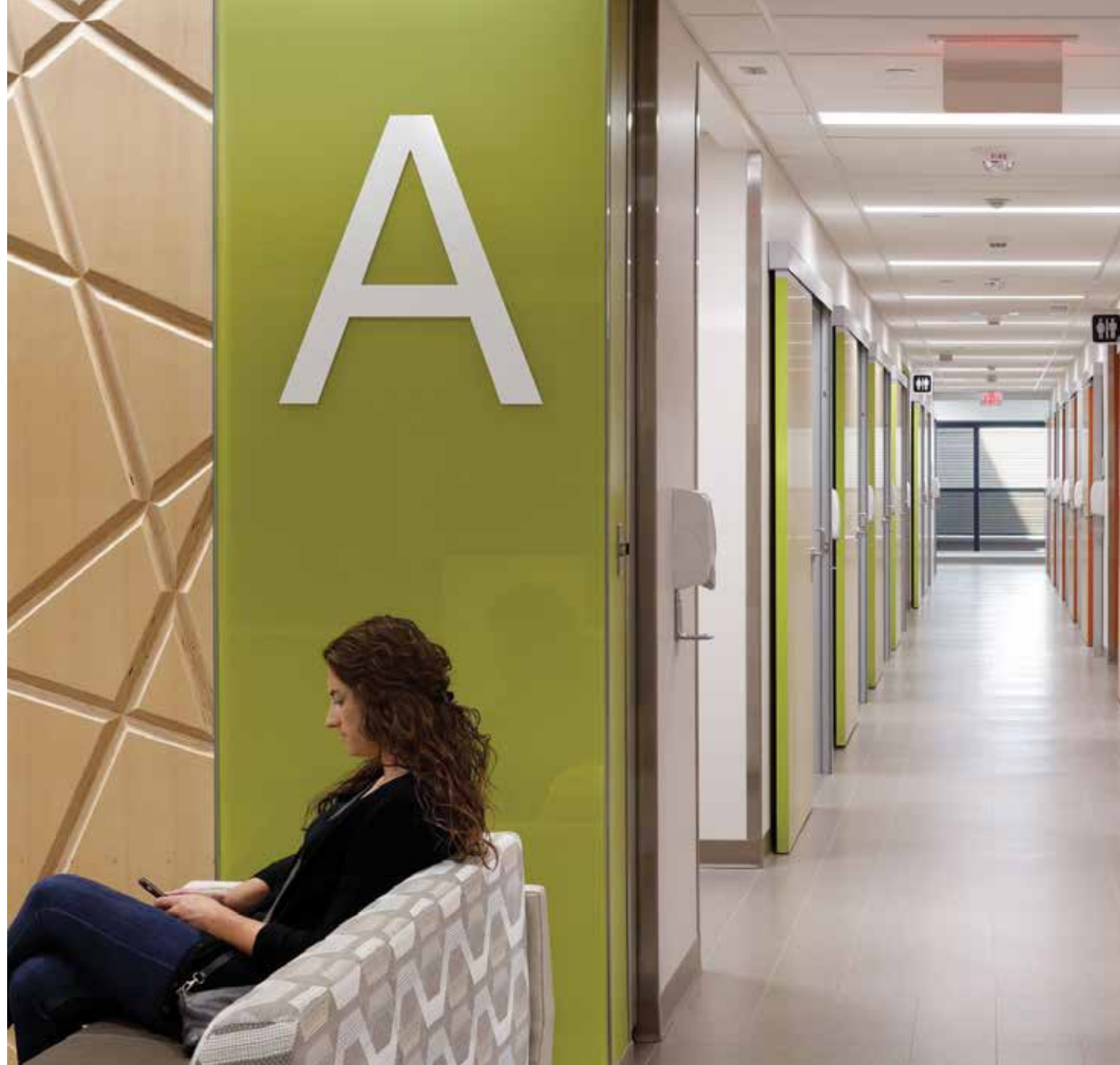



SPACE SAVING DESIGN

SLIDE DOORS

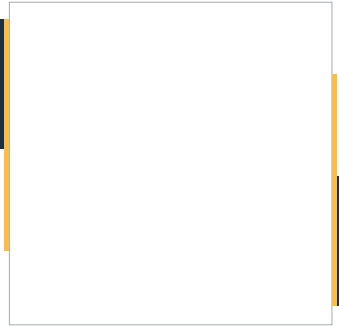

SWING DOORS



A Story of Space Savings

It's time to pivot from traditional swing doors and roll with the space-saving benefits of sliding door solutions. With swing doors, the nature of their swing path can prove problematic in space-restricted areas. When the door is open, it can become difficult for occupants to maneuver around or through the space.

One of the benefits of sliding door systems is they eliminate the space needed for a swing path, freeing up clearance and allowing for fluid, open pathways. Take AD Systems' ExamSlide™ door, as an example. The space-saving design of this door saves up to 30 sq. ft. when compared to a swing door.

PRODUCT SOLUTIONS

Conquer common challenges in healthcare facilities, offices, collaboration spaces, and more.



ExamSlide™

Our flagship, surface-mounted, sliding door system was developed in collaboration with architects to meet the demands of clinics and medical offices. Add proven acoustical performance, durability, and hardware functionality to your design. Flush wood, wood with glass lite, or aluminum stile and rail door leaves are available.



OfficeSlide™

Get the most form and function for your meeting rooms, offices, and collaboration rooms. This highly customizable solution expands on the performance and functionality of the ExamSlide door to incorporate sidelites, transoms or custom interior storefront elevations.



FireSlide™

Turn up the heat on your fire-rated designs with our fire-rated flush wood door or wood door with optional fire-rated vision panel (up to 100 in²). This system is tested in accordance with UL 10B Standard for Fire Tests of Door Assemblies for up to 45 minutes. It is available in the same profile dimensions as non-rated door systems.



AutoMotion™

We set the future in motion with our automatic sliding door solution. Our latest product offering meets customer needs for acoustic isolation and space-saving design, along with the added benefit of easy, hands-free access. These quiet low-energy operators can be added to ExamSlide, OfficeSlide or InsetSlide systems.



SuiteSlide™

This economical solution is perfect for projects that don't require acoustic mitigation or advanced hardware functionality. Like all of our products, SuiteSlide is a well-designed, single-source door assembly that's tested for resilience. It's perfect for senior living/multifamily residential, single family residential, or hospitality applications.



INSETSLIDE™

This exciting innovation gives you all the functionality of our other sliders in a sleek inset design that fits within a wall opening. Enjoy the same exceptional design, performance, and hardware options as our surface-mounted systems. InsetSlide's integral sidelite can accommodate glazing or other infills up to 1" thickness.



CASE IN POINT

University of Iowa Hospitals and Clinics (UIHC) Heart and Vascular Center

At the University of Iowa Hospitals and Clinics (UIHC) Heart and Vascular Center, commercial sliding doors were specified for dual entry exam rooms with colored edge details on the patient entrance and the physician entrance for improved wayfinding. The project also featured aluminum and full-lite glass doors used in treatment rooms. Beyond supporting movement patterns, bright frames or pops of color on sliding doors can match an organization's overarching look and feel, tying interior aesthetics to a brand. All doors are supplied by AD Systems to ensure proper fabrication, construction and warranty.



ACOUSTIC PERFORMANCE

To accommodate the need for acoustic privacy and ensure patient/provider confidentiality, AD Systems supplies doors with gasketing and optional drop-down bottom seal features to effectively seal all four sides of the sliding door leaf. The result is a tight perimeter with excellent sound abatement properties. For example, ExamSlide doors provide NIC (noise isolation class) values up to 39. This meets or exceeds the Facility Guidelines Institute's target for speech privacy in exam rooms, and is a key safeguard for protecting patient privacy in a range of room settings.



1. High quality uniform finish



2. **Strong Back Track** designed to accommodate real world construction



3. End caps with no visible fasteners for a clean look from all angles



4. Narrow profile but heavy gauge perimeter frame protects wall and resists impact



5. Superior acoustic properties rated to NIC 39 and STC 34



6. Infinite choices of materials, doors, finishes and glazing



THE AD SYSTEMS DIFFERENCE

Superior sliding doors require cutting-edge components. AD Systems has forward-thinking hardware and resources – so your vision stays on track.

7. High quality commercial grade hardware



8. Soft closers, tested to 150,000 cycles, dampen the closing speed and force at both sides of the door, ensuring quiet and safe operation



9. Quality fit and finish - concealed floor guides, fasteners and fully finished door edges



10. Various optional hardware such as self closers that enhance the user experience

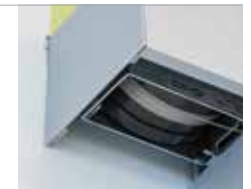

FRAMING

Looking for design that borders on greatness? The framing design & finishing options for our interior sliding door solutions support your goals for creating functional and beautiful spaces. Select a frame design and finish to enhance the décor or make a statement.

Wraparound Frame

This unique solution is designed to protect wall openings and aid in superior sound performance. AD Systems frames feature a Kynar® finish (as opposed to clear anodized), so touch-ups are easy and the designs look great for years. The wall thickness adds resiliency from impact.

The frames are also designed to accommodate variations in wall construction, ensuring quality fit and finish. The integral jamb “stile pocket” receives the door leaf, ensuring acoustic performance and strike plate integration.

Wall Thickness:

- Standard wall thickness options: 4-7/8", 5-1/2", 7-1/8"
- Custom: Custom wall thickness designs are available

Finishes:

Painted hardcoat finish by Kynar® (meets AAMA 2604)

- Standard Color: Light Sequin (match to clear anodized)
- Custom Color: Color match to almost any paint color

ELEVATION VIEW: Opens to left

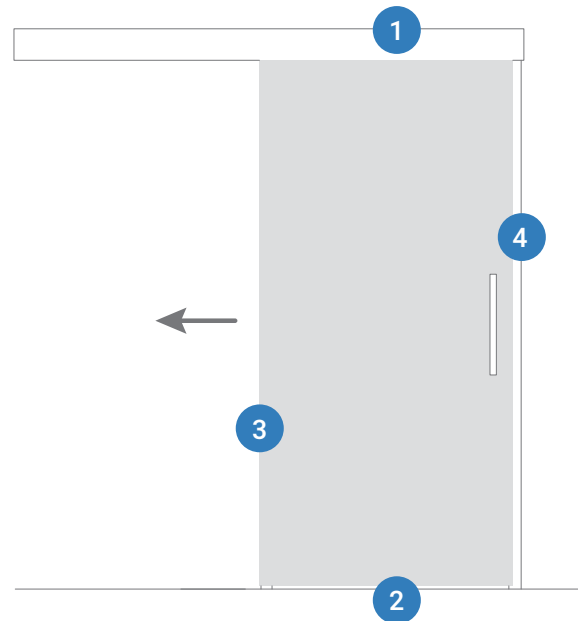

1 HEAD @ OPENING
Typical

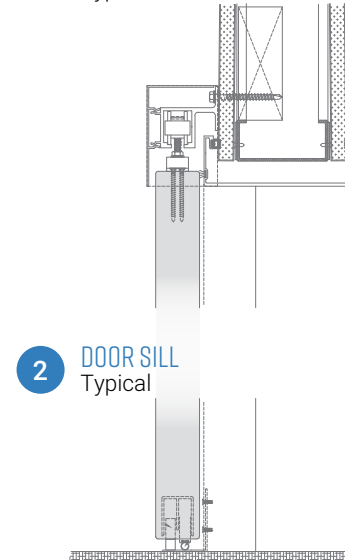

2 DOOR SILL
Typical

3 JAMB @ SILL SIDE

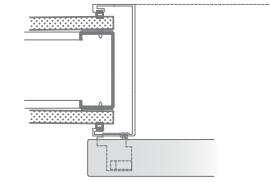

4 JAMB @ PULL SIDE
Typical

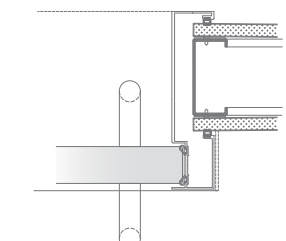

THE AD SYSTEMS DIFFERENCE: THAT'S A WRAP!

Our flexible wrap frame allows for installation on varying wall conditions.

FIXED LITES

THE AD SYSTEMS DIFFERENCE: PARTNERING UP!

All non fire-rated systems available as biparting pairs.

For ExamSlide™, OfficeSlide™ and InsetSlide™ designs featuring fixed lites (sidelites), AD Systems offers a variety of sill profiles.

- Standard
- Full Depth
- U-Channel

A STANDARD SILL OPTION USING IM-01 At SideLite

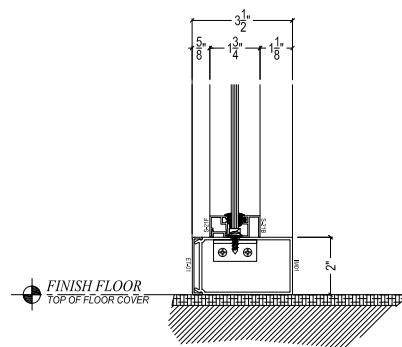

B FULL DEPTH OPTION At SideLite

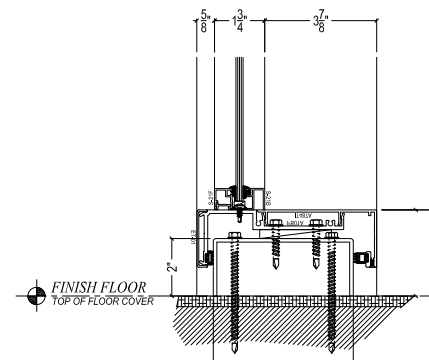

C U-CHANNEL OPTIONS At SideLite

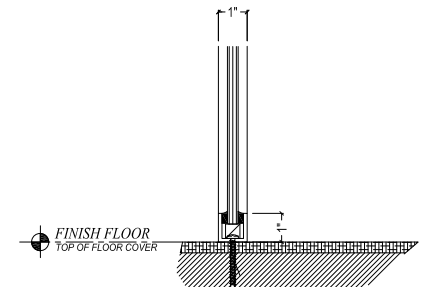

DOOR LEAF DESIGN

Inspiration is fueled by having many options. From wood doors of any species to laminate, glass and aluminum options, AD Systems offers endless possibilities.



CASE IN POINT

North Creek High School

Our single leaf sliding doors were used in “collaboration cubes” and teacher planning rooms to support a collaborative culture, while also providing space savings, daylighting, and sound attenuation.

The wood sliding doors featured full glass lites and sidelites for daylighting and visual communication. The glazing captures the ample natural light that filters through the high school, increasing energy efficiency, while supporting collaboration.

With a soft-closing dampening system, acoustic jamb gaskets and drop-down bottom seal features, it’s possible to seal all four sides of a sliding door for optimum privacy. These features enable sliding doors to be on par with most swing doors, providing Noise Isolation Class (NIC) values up to 39.



THE AD SYSTEMS DIFFERENCE: STRENGTH IN NUMBERS

With over 50,000 doors installed, you can trust the proven performance of AD Systems.





WOOD DOOR LEAVES

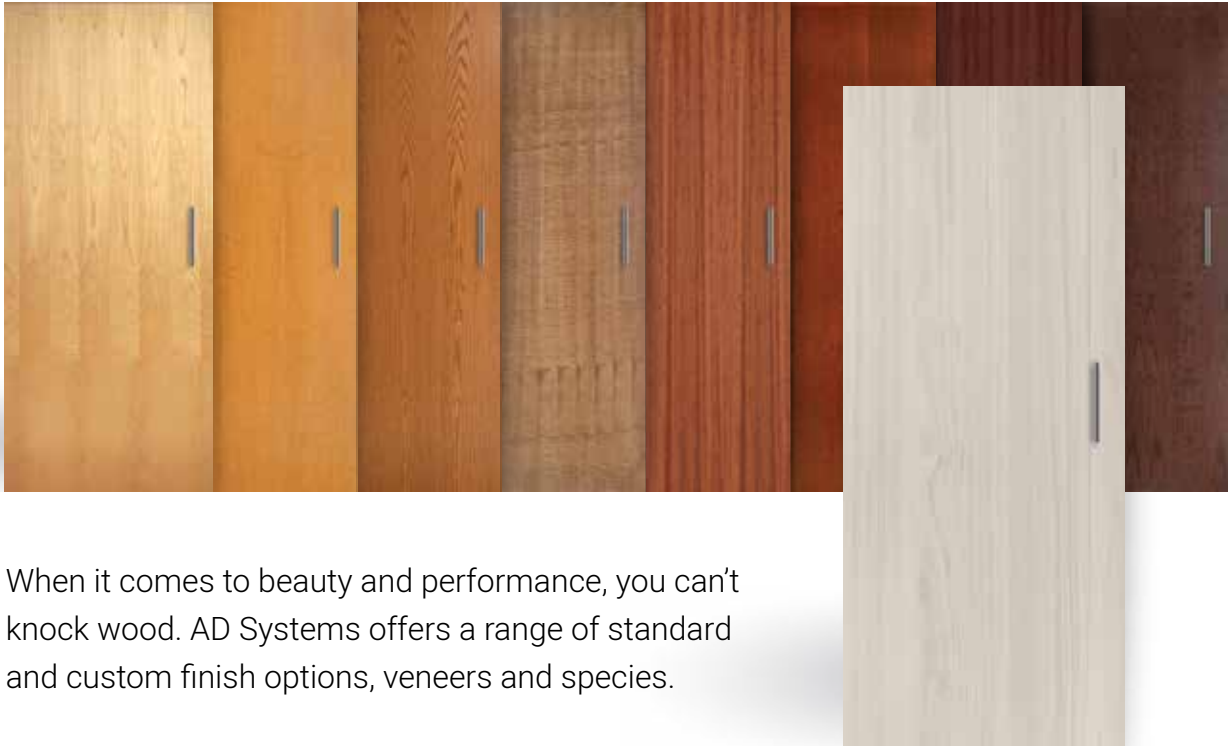

When it comes to beauty and performance, you can't knock wood. AD Systems offers a range of standard and custom finish options, veneers and species.

Wood Doors

CORE:

- SCLC heavy duty core for acoustics and durability

LEAD LINED:

- Lead lined doors are available for radiation shielding

VENEER:

- Natural woods with standard or custom stain finishes
- Plastic laminates like Wilsonart®, Formica®, Nevamar® and Pionite®
- Specialty high impact veneers such as Paladium® with In-Pro® IPC Rigid Vinyl or Acrovyn® door protection

ALUMINUM DOORS & GLAZING

Aluminum Stile And Rail Doors

These sleek aluminum profiles are available in standard silver or custom color finishes.

STANDARD:

- 4" stiles and rails
- Standard color light sequin finish

OPTIONAL:

- 10" bottom rail
- Custom colors
- Other 1-3/4" specialty doors available upon request



THE AD SYSTEMS DIFFERENCE: SUPPORTING OUR TROOPS

We've done over 1,500 openings for Veterans Affairs Medical Centers ... and we have over 200 more in the works!





GLAZING

AD Systems offers a variety of glass types and options to help you meet your desired aesthetics without sacrificing the performance features of a solid door. Choose different opacities, colors, designs and even materials such as markerboard, solid surface or resins. Or go high tech with integral louvers or switchable glazing.

Tempered Glass

- 1/4" clear or frosted

Laminated Glass

- Clear, translucent, white or colors

Integrated Blinds

(for privacy in areas like exam rooms)

- Glass can be combined with Vision Control® integrated cord-free louvers available from industry-leading Unicel Architectural. Its advanced louvered glazing technology eliminates strings, ensures alignment and requires no maintenance

Glass Markerboard

- Great for offices, exam rooms, etc.

Art Glass

- Imagine the same beautiful art glass in your overall design translated to sliding doors for a cohesive design
- Most other specialty glazings (up to 1" thickness)



OPTIONAL SYSTEM COMPONENTS

AD Systems offers a variety of optional components that further enhance the door systems' ability to operate smoothly, safely and efficiently.

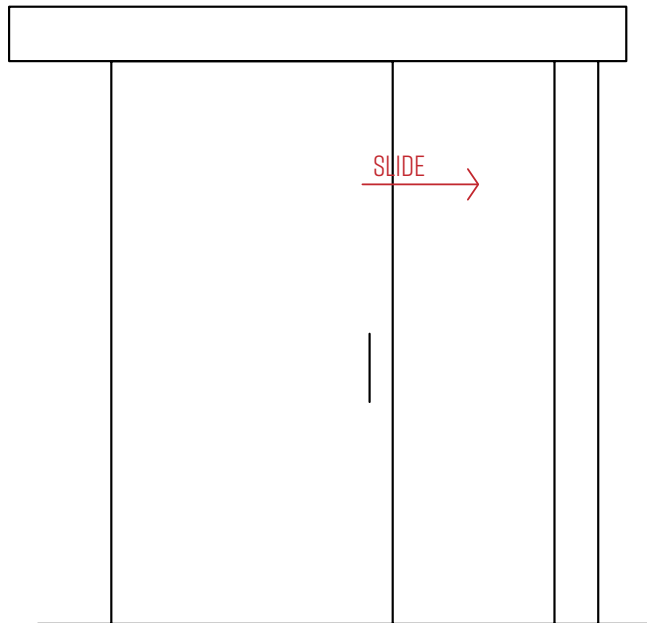

Smoke-Rating

UL 1784 Smoke and Draft Control Assemblies

- Smoke-rated applications
- Doors with air leakage performance as per independent test lab results
 - <https://bpdirectory.intertek.com/Pages/Report.aspx?ReportName=Listing&SpecID=44151>
 - Potential application in pressurized environments

AD Systems smoke-rated configuration comes equipped with self-closer, automatic door bottom and positive latching hardware (AD 6000).



Synchro Door Drive

Coordinator for pairs of doors



Spring Self-Closing Mechanism

Adjustable tension/speed, concealed behind valance

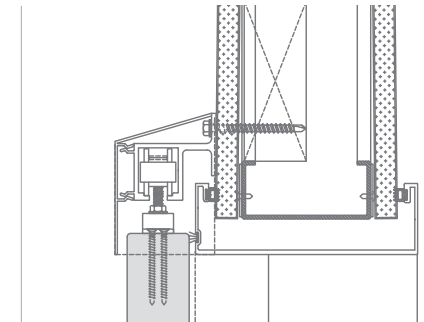

Valance

Available in sloped configuration (square configuration is standard)

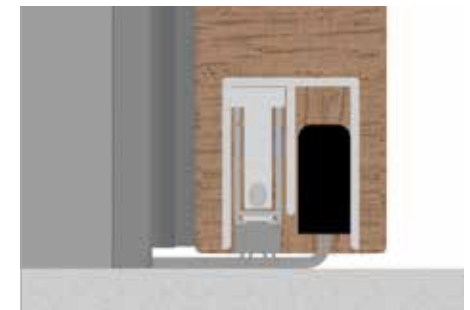

Concealed Automatic Door Bottom

For enhanced acoustical performance - acoustical performance reports design available upon request

FIRESLIDE™

Fire-Rated & First

At AD Systems, our conviction burns with curiosity. This persistent spirit of innovation drives us to seek new ways to drive the industry and support your design. One such example is FireSlide™ -- the industry's first, patent-pending, fire-rated, wood sliding doors.

FireSlide™ surface-mounted, top-hung single-leaf doors offer the clean, modern aesthetic of sliding flush wood doors, while achieving a 45-minute UL 10B fire rating. Fire-rated doors now available with up to 100in² FireLite® NT fire-rated and impact-safety-rated clear ceramic glass. FireSlide™ doors save significant space when compared to a swing door and defend against fire, while still providing the acoustic performance, hardware options and reliability you expect from our sliding door systems.

Exciting things happens when you fire up the imagination.

STANDARD FEATURES:

- Achieves a 45-minute UL 10B fire rating
- Space-saving design saves significant space when compared to a swing door
- Acoustic seals on three sides to help enhance privacy and reduce indoor noise
- Heavy-duty, top-hung roller systems for smooth operation
- FireSlide features self-closers, soft-close dampener and self-latching hardware
- Vision panels of up to 100in² of FireLite NT 3/16" (5 mm) fire-rated and impact-safety-rated glass ceramic by TGP. FireLite NT is classified and labeled by Underwriters Laboratories, Inc.®
- Same frame profile dimensions as AD Systems' non-rated ExamSlide™ doors

HARDWARE OPTIONS:

- Self-latching hardware with optional privacy or key lock functionality
- Electronic access control available
- Optional magnetic hold open

1-3/4" DOOR OPTIONS:

- Flush wood door with a range of laminate and natural veneer options
- Clear opening sizes up to 40-1/2" by 83-3/8"

HARDWARE SELECTION GUIDE



If you are looking for the highest-quality hardware for your commercial sliding door systems, AD Systems is a lock. All of our doors feature Allegion hardware such as Schlage® lever handles. It's commercial hardware that stands up to commercial use.

Door Pulls

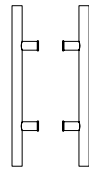

LADDER PULLS:

- 16 in US32D - Standard
- Other lengths and finishes available

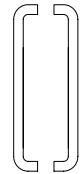

WIRE/D PULLS:

- 12 in US32D – Available

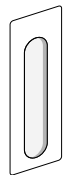

SPECIALTY PULLS:

Flush, full-length, anti-ligature and other pull options to meet your design needs available

Deadbolts (AD5000)

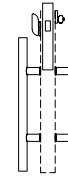

AD5450P-LP-630 OFFICE:

- Deadbolt Cylinder & Thumbturn with Ladder Pulls

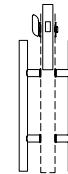

AD5440-LP-630-I PRIVACY:

- Deadbolt with Indicator (or Coin Override) & Thumbturn with Ladder Pulls

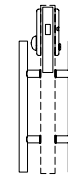

AD5440-LP-630-SI PRIVACY:

- Deadbolt with SECTIONAL Indicator & Thumbturn with Ladder Pulls
- *Also available in SFIC and FZIC*

SECTIONAL CYLINDERS:

- The 180 degree visibility indicator offers unparalleled visibility and flexibility.

Self Latch / Single Action Egress Lever Lock (AD6000)

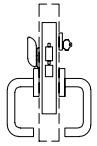

AD6450P-L03-630 OFFICE:

- Lock with Cylinder & Thumbturn, with Levers

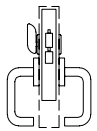

AD6440-L03-630 PRIVACY:

- Lock with Indicator (or Coin Override) & Thumbturn, with Levers

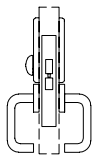

AD6440-L03-630-SI PRIVACY:

- Deadbolt with SECTIONAL Indicator & Thumbturn with Levers

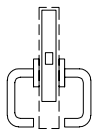

AD6010-L03-630 PASSAGE:

- Lock Passage Latch, with Levers
- *Also available in SFIC and FSIC*



VACANT

Electronic Locking Options

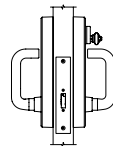

ELECTRIC STRIKE WITH CONTROL TRIM WITH SINGLE ACTION EGRESS:

- Available in fail safe and fail secure. 12v & 24v options

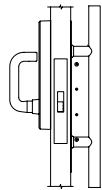

OPTIONAL CONTROL TRIM WITH LADDER PULL AND INTERIOR LEVER



MAGNETIC LOCK:

- Compact Mortise with 850lb of Holding Power
- 10"L x 1-7/16"W x 1-1/2"D machined into door leaf

THE AD SYSTEMS DIFFERENCE: HARDWARE THAT'S HARD TO BEAT

Our hardware is not your average variety.
It's all commercial grade that's built to last.



AUTOMOTION™

In today's environment, building professionals are seeing an increased demand for touchless products which help make more hygienic, accessible and convenient spaces a reality. This is especially true for inpatient healthcare facilities. Since these spaces feature frequently touched surfaces, innovative solutions are required to help prevent the transmission of viruses. In these cases, a door with automation becomes ideal.

AutoMotion™ Low-Energy Operator System

Our AutoMotion sliding door system allows occupants to wave a hand, step on a footpad or use other actuator options to initiate a completely touchless door experience. Automating interior sliders enhances ease of use and reduces the spread of germs and bacteria making these excellent choices for high traffic areas, restrooms and utility spaces.

- Compatible with ExamSlide™, OfficeSlide™ & InsetSlide™ sliding barn door systems
- Single leaf or bi-parting designs
- Options for fixed lites
- Variety of activation devices, safety and security accessories



AUTOMOTION™ OPTIONS

THE AD SYSTEMS DIFFERENCE: ACCESS CONTROL IS KEY

Looking for the finishing touch? We provide a variety of contact-free solutions for high-traffic areas.

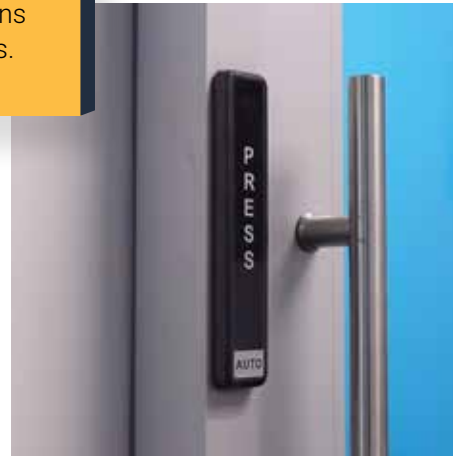

Standard with every system, inside and outside activation devices:

- Touchless hand sensor switch
- Various wired or wireless push bottom

OPTIONAL COMPONENTS:

- 5-function remote control
- Solenoid bolt lock
- Foot sensor switch
- Battery back-up

SAFETY SENSORS:

- Photocell lens
 - Standard on all our systems, these lenses prevent the door from closing if either light beam is interrupted by a person crossing the opening
- Optional overhead presence detector
 - Prevents door from closing if presence is detected within a small range of the door opening

CUSTOMIZATION

AD Systems is a pioneer when it comes to providing custom solutions. Since 2008, we have worked collaboratively with owners, architects and contractors to meet job specific requirements and designs. Bring us your project needs and our engineering team will adapt a sliding door solution.

THE AD SYSTEMS DIFFERENCE: ANYTHING IS POSSIBLE.

Create your own
custom designs for
your next project.
We are always
open to new ideas.

Barrier Free – Bed Lift Sliding Door Assemblies

The Barrier Free design option adapts our standard ExamSlide™ door to accommodate a bed lift, allowing for patients to be transported by lift through a sliding door opening. This is an increasingly popular solution for inpatient restrooms.

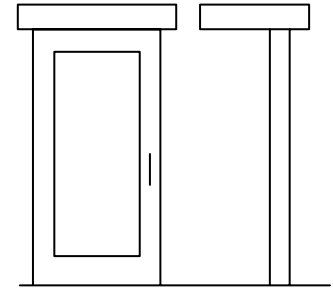

90-Degree “Magic Cube”

Commercial sliding doors are already space efficient, but this magical solution takes smart design to the next level. It can be used when space is restricted, an opening isn't big enough, or a wall butts up against a slider and prohibits functionality. Our 90-degree, bi-parting “magic cube” is designed with two sliding doors opening in perpendicular directions. Both panels can be open at the same time, as well as have one open while the other is closed. This is an innovative way to get a large opening with limited wall space.

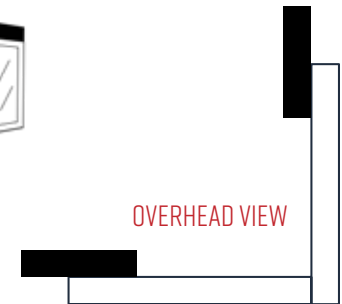

Telescoping Doors

When a wide opening is needed but space is limited, AD Systems can provide telescoping doors that slide and stack on top of each other. These doors aren't typically used in high-traffic areas, but rather in flexible spaces with maximum openings and minimal footprint. AD Systems can supply up to 3 telescoping aluminum doors in this inset system.

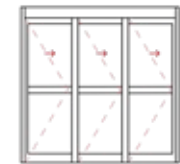

THE AD SYSTEMS DIFFERENCE: INPATIENT INSPIRATION.

We offer a variety of space-saving, wellbeing solutions for inpatient applications. Plus, exciting new systems are in the works!

Oversized Doors

Flexible spaces demand flexible and agile solutions. Our oversize doors are at home in applications like adjoining classrooms...anywhere you want the flexibility to connect or create separation between spaces. With our oversized doors, a single leaf can be 7' wide (15' per pair). We see a lot of these in flex spaces. Imagine two adjoining classrooms, restaurant kitchens, anywhere you want to close the space off, but you need to have a large flow.

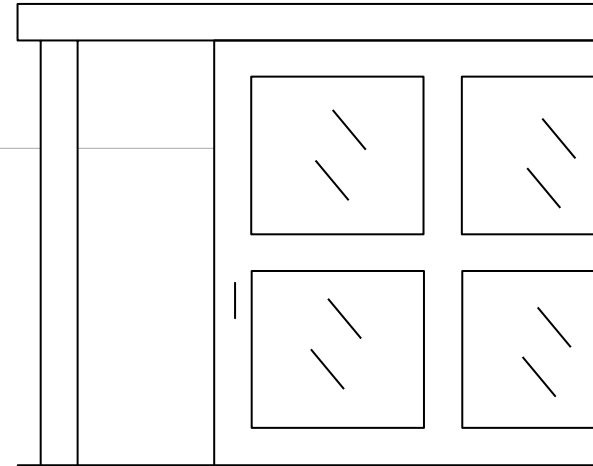

Door Extenders

Our innovative solutions are all about adaptability and durability. We developed our door extenders to minimize cost impacts of oversize wood doors. Door extenders are a great way to make wood doors larger for less. These durable aluminum edge profiles are also an excellent solution for door protection.

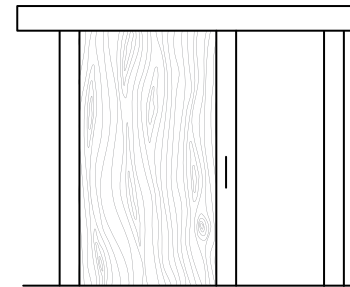

Swing Doors

AD Systems is an expert when it comes to commercial sliding doors, but we can also include swing doors to match your sliding doors as well. This is ideal for projects where a complete, synergistic, high-quality system solution is desired. Because of our relationship with Allegion, who are true swing door experts, AD Systems can offer integrated solutions for hardware and frame finishes. Leverage our team's knowledge in swing doors and get everything you need from one source.

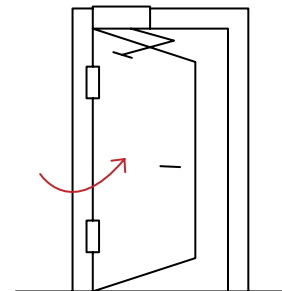

SPECIALTY SOLUTIONS

Looking for something different? We deliver an assortment of unique solutions like lead-lined doors, smoke-rated systems to UL 1784 Standard for Air Leakage Tests of Door Assemblies, and other opening protectives.



AD
SYSTEMS™
HIGH PERFORMANCE DOORS

ALLEGION™

Choose the pioneer in commercial sliding door systems, who continues to innovate with industry-changing design and functional options. Work with one source who can engineer anything you can dream up. Then enjoy the world-class service and support befitting of these world-class products.

Reach out to us today at:
specadsystems.com
425.740.6011

COPYRIGHT 2021 ALLEGION. ALL RIGHTS RESERVED.

